



How to Attach Butler Robotics to a Handi Quilter

Bag #

Contents

Picture

12

White Belt, eyebolts, belt brackets



26

Stylus, zip ties, anchor



28

Motor Pulley Cover



29

White belt brackets



39

Display Bracket



59

Black belt Bracket, Black Belt



60

Front Carriage Bracket



61

Rear Idle Bracket



62

Wires



Attach the Front Carriage Bracket

1

Attach the front carriage bracket to black motor box using the provided screws.

(Bag #60)

Front Carriage Bracket

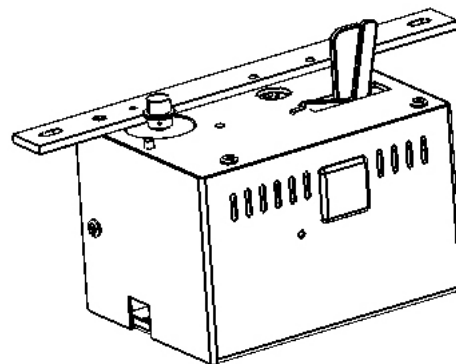
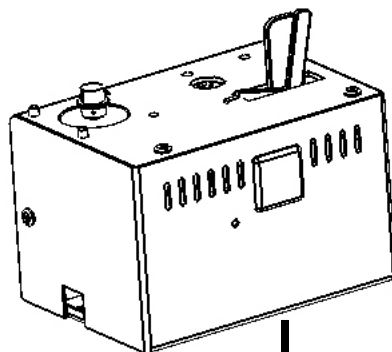

Black Motor Box

2

Install Motor box bracket to the front of the carriage.

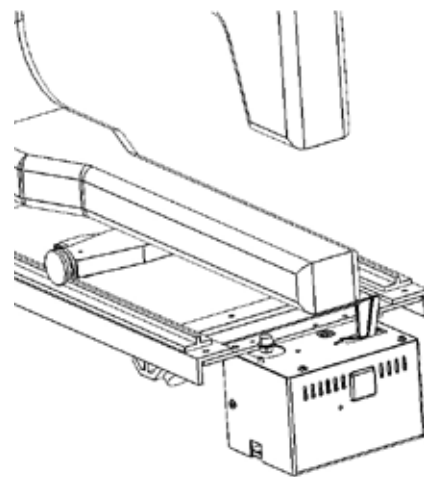
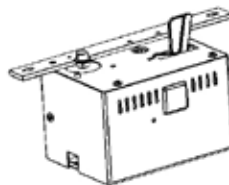
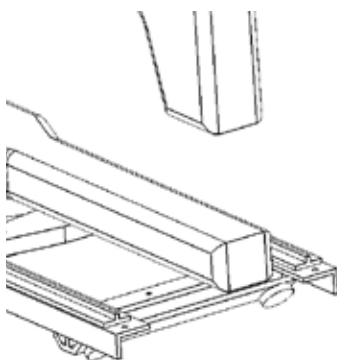

Attach the Rear Idle Bracket

- 1 Attach the rear idle bracket to the rear of the carriage.

(Bag #61)

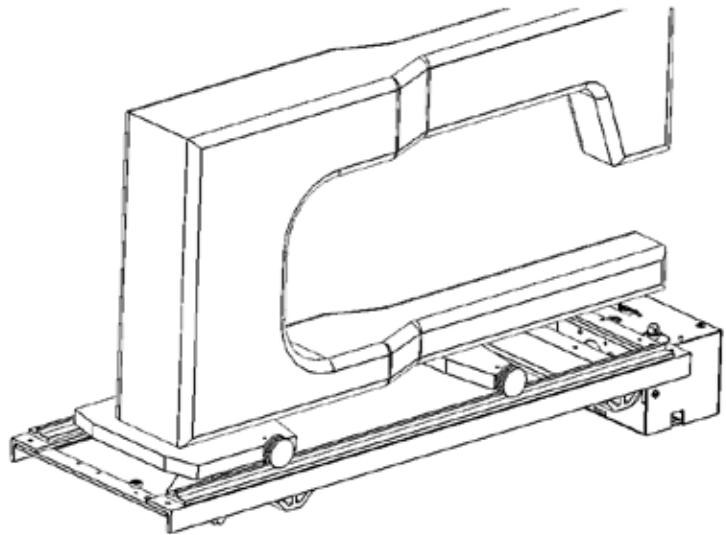
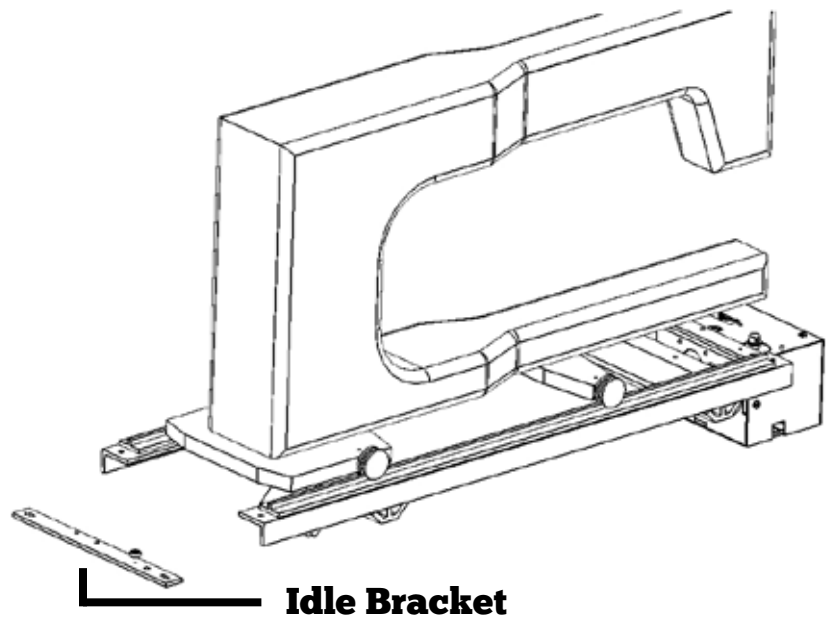

Install Black Belt

- 1 Attach the two black belt brackets together using the provided winged screw and screw.

(Bag #59)

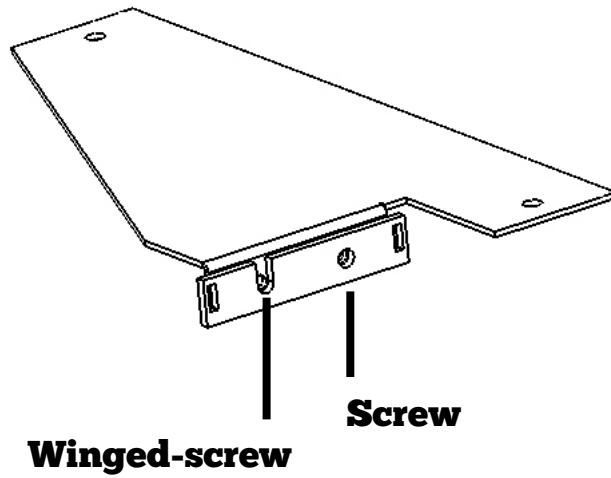
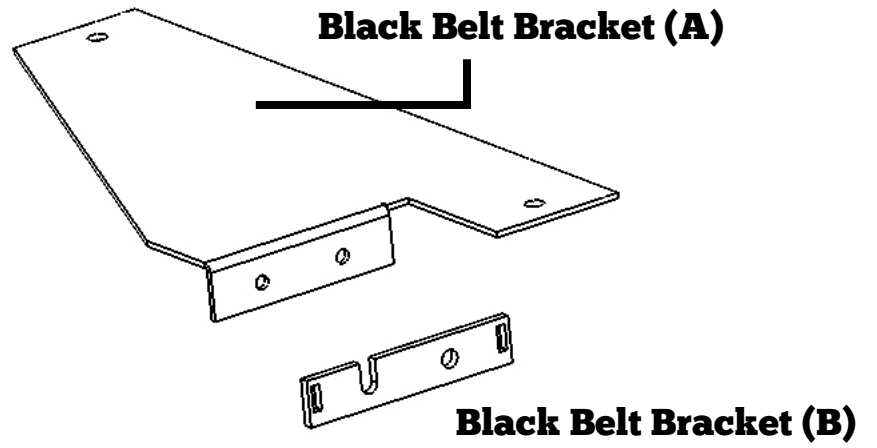

2

Install black belt assembly to the underside of the front carriage wheels.

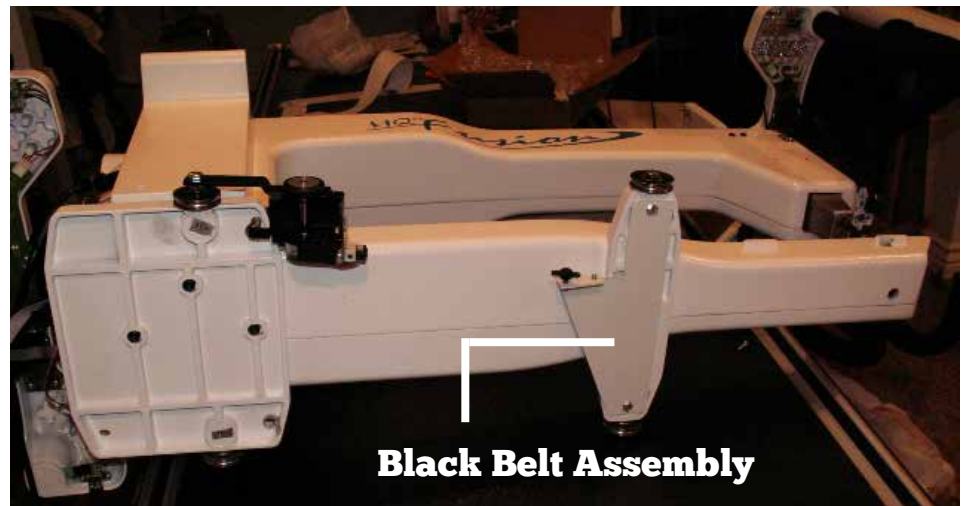
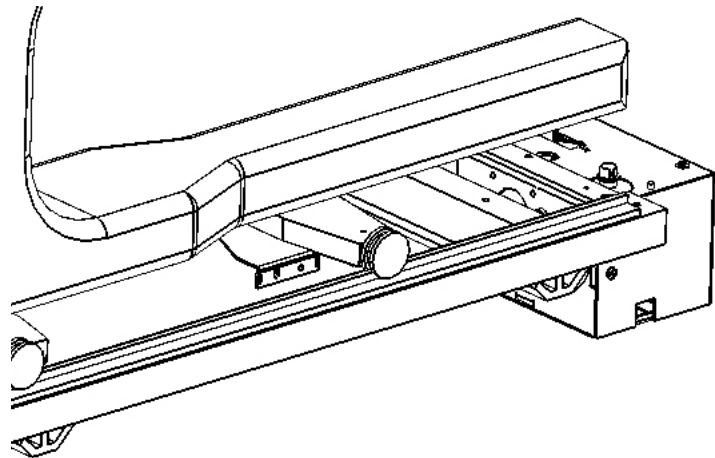
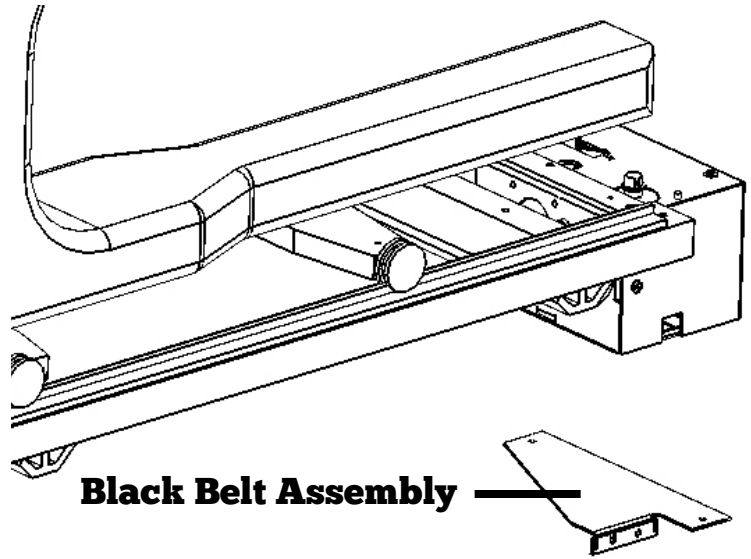

3

Loop the black belt (shown at right in red) around the rear idle pulley and the motor box pulley.

Attach the black belt to the belt bracket using belt clamps.

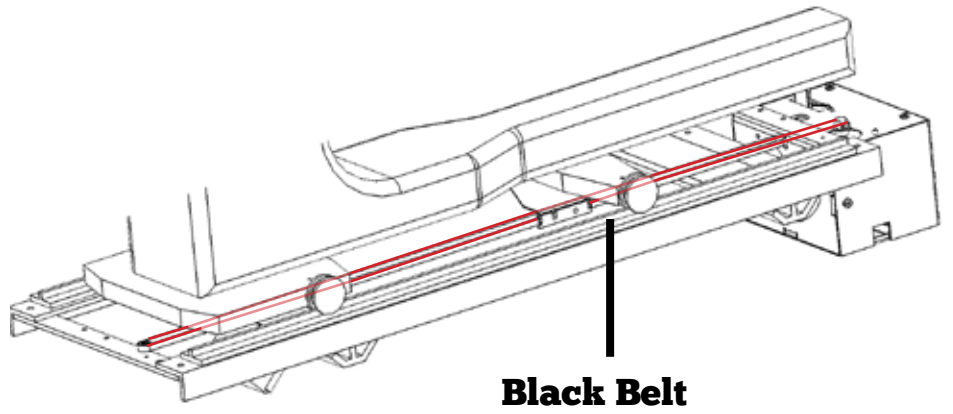

Install White Belt

Installing onto a Baby Lock Pearl Frame

1

Sandwich the white belt brackets onto the each end of the frame using the provided long screws.

(Level the belt and brackets with the pulley on motor box.)

(Bag #29)

(Bag #12)



2

Attach the white belt to the I-bolt using the belt clamps to install into the belt bracket.



Install the eye-bolt into one belt bracket, stretch white belt the length of the frame, belt teeth facing up.

Attach the other end of the white belt to the remaining eye-bolt and install into opposite belt bracket. (Use the belt clamp to eliminate excess belt length.)



Install White Belt (Cont'd)

Installing onto any other frame

1

Sandwich the white belt brackets onto the each end of the frame using the provided long screws.

(Level the belt and brackets with the pulley on motor box.)

(Bag #29)

(Bag #12)



2

Attach the white belt to the I-bolt using the belt clamps to install into the belt bracket.

Install the eye-bolt into one belt bracket, stretch white belt the length of the frame, belt teeth facing up.

Attach the other end of the white belt to the remaining eye-bolt and install into opposite belt bracket. (Use the belt clamp to eliminate excess belt length.)



Install Display

- 1** First, Insert SD Card into side of display and align the display to the top of your machine.

(Bag #39)

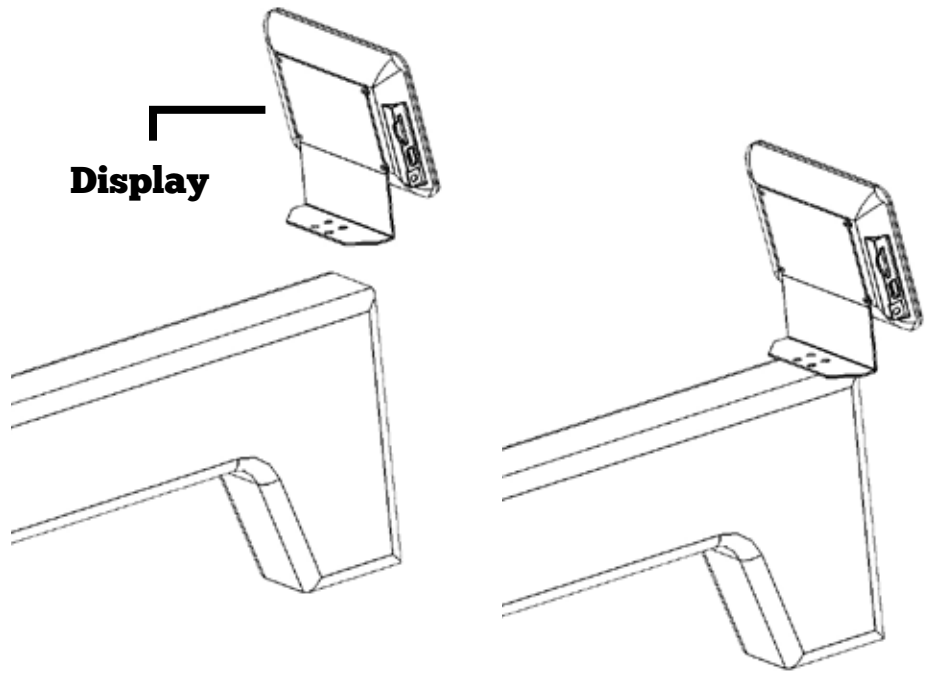

- 2** Use the three long screws from your handle bars to attach the display to the machine.

Connect Wires

- 1 Plug the display wire into the display cable port and the other end into the remote port on the black motor box.

(Bag #62)

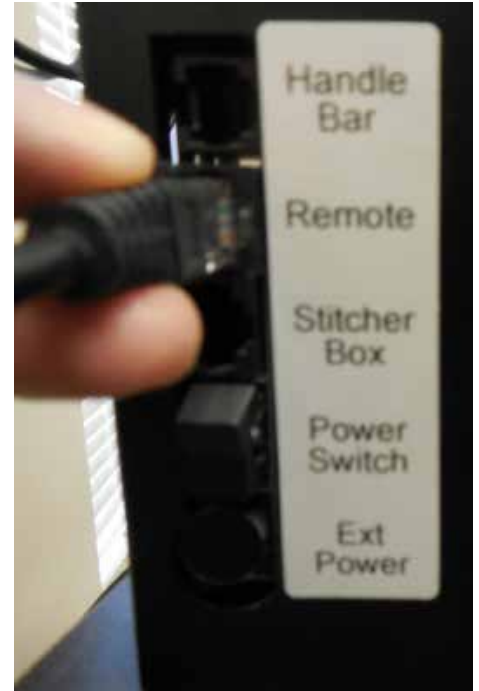
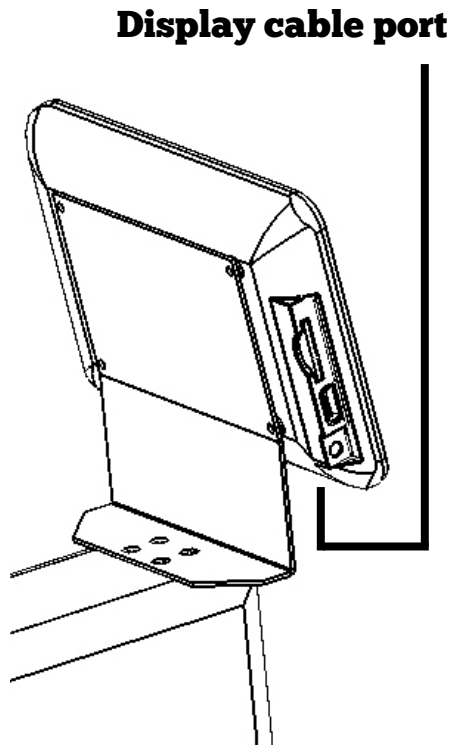

- 2 Plug one end of the handle bar wires into the handle bar port on the black motor box.

FOR FUSION:
Plug the remaining end into the micro handle port on the underside of your handle bars.



2

FOR AVANTE:
Unplug original handle bars, insert provided junction, re-plug in original handle bars and plug remaining end of handle bar wire into side port on junction.



Set Machine Type

- 1 Power on the display, go to Setup > Advanced and set the machine type to HQ.

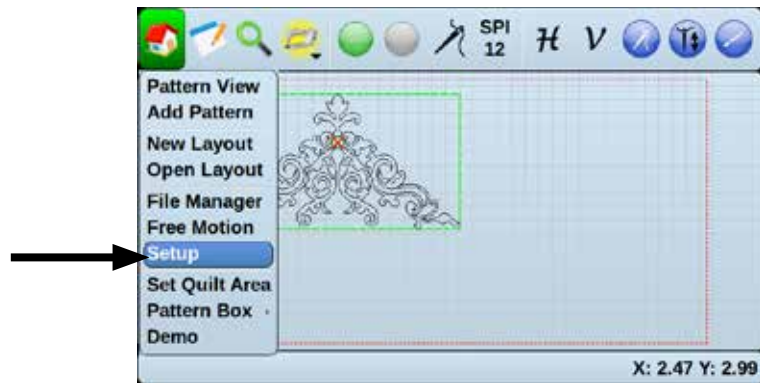

Check Belt Tension

1 A correctly tensioned belt won't be as tight as a piano string but isn't as limply sagging.

Adjust belts as necessary.

Appendix A - How to use Belt Clamps

A belt clamp consists of two clamps and two screws.

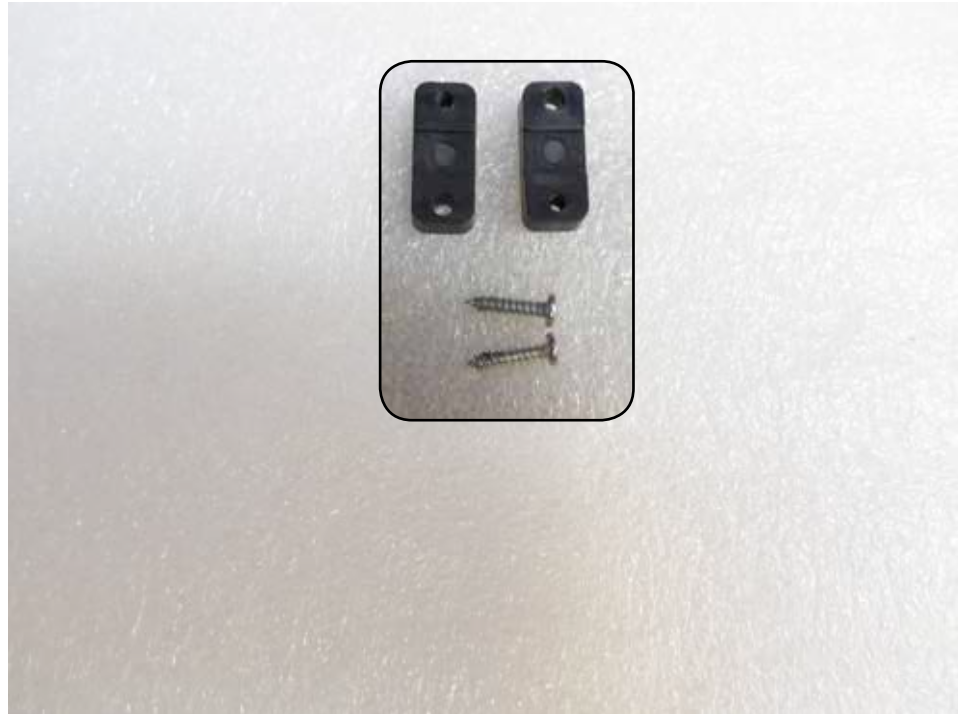

- 1** Using a Phillips screwdriver, insert each screw on opposite sides of the clamps and tighten halfway.

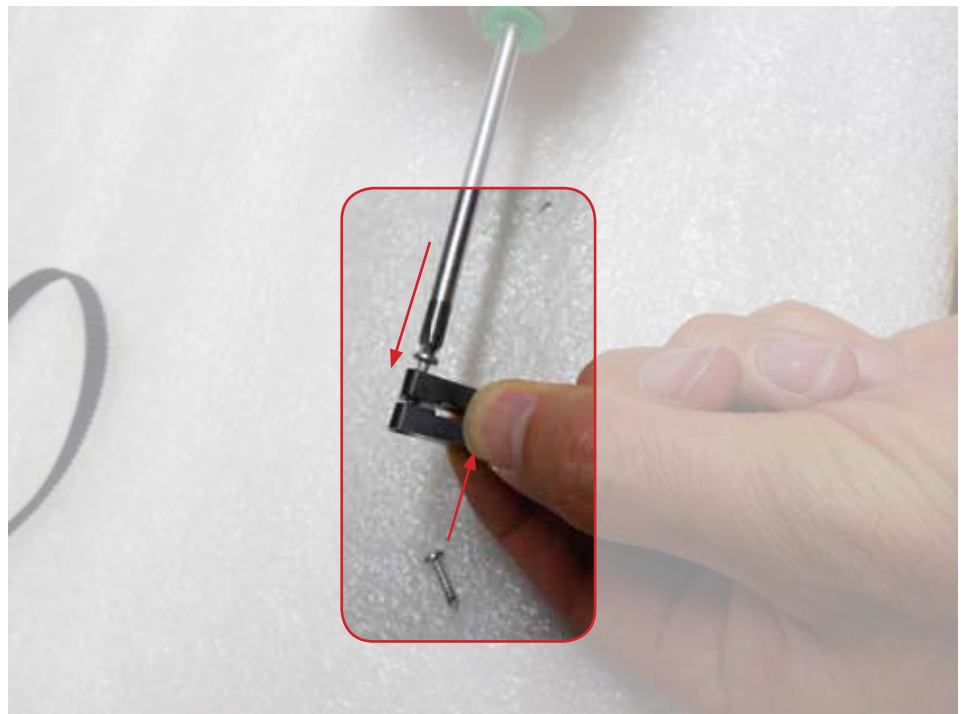

2

Thread the belt between the clamps, loop it around and reinsert it between the clamps.



3

Align the belt teeth, then finish tightening the clamps.





Still need help?

Visit quilt-ez.com to learn how to contact us and find additional help material.